

PRO 5



Quick Reference Guide

1

Visually Inspect the System

1A



Check the thrusters.

Inspect the propellers, verifying that each has 3 blades and they are free to spin.

GOOD WORN

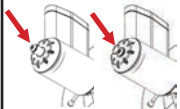

Inspect the thruster telltales and look for signs of oil leakage.

1B

Inspect for water inside the camera housing.

1C

Inspect the entire system for signs of damage, loose, or worn parts.

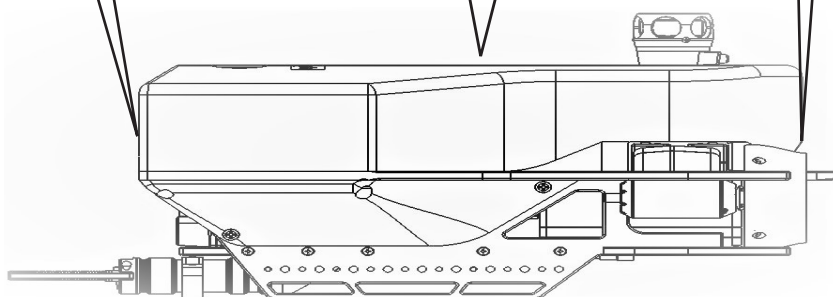

VideoRay



GREENSEA

2

Connecting & Powering On

- ⚠️ WARNING:** Do not connect or disconnect cables while system is powered.
- ⚠️ CAUTION:** ALL ROV submerged connections must be terminated.
- ⚠️ CAUTION:** Follow these steps in order when starting the system.

Connecting the System

1. Remove the tether caps and connect the female end of the tether and strain relief to the ROV. See figure 2B. (Store caps in a secure location)
2. If not already connected, connect the male end of the double ended connector **26A** to the Operator Control Console (OCC). **26**
3. Connect the male end of the tether to the female end of the double ended connector. **26B**
4. Remove the ROV float block bolts and remove the float block.
5. Inspect all 5-pin and 9-pin connectors to ensure they are seated and then Replace and secure the float block. See figure 2C. CAUTION: If the connectors are not fully seated, clean, lubricate, and reseat them.
6. Connect the hand controller to the OCC controller USB port. **24**
CAUTION: Do not connect more than one hand controller to the system at a time.
7. Connect the keyboard to the OCC keyboard USB port. **25**
8. Confirm that the ROV POWER MAINS is fully depressed.
9. Connect the OCC power cord to the OCC and a power source. **18**

10. Turn on the OCC.  **19**

11. Turn on the ROV POWER MAINS.
Twist the Red Power Mains button clockwise.

12. Start the Pro 5 control software.

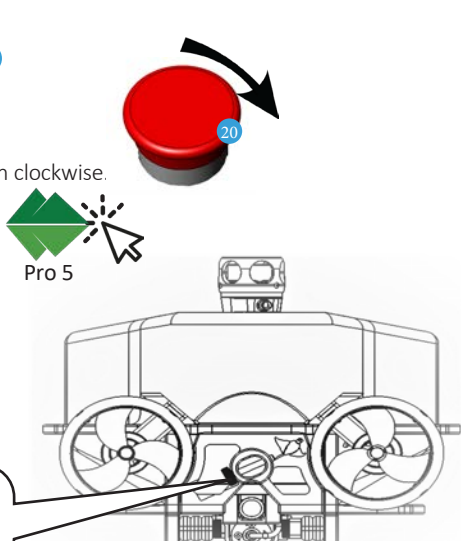

2B

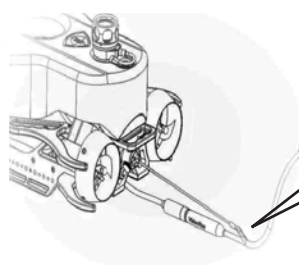

Test the strain relief to verify the stress is on the cable not the tether or connector. **35**

2C

If the connectors are separated, do not place the system in water. Clean, lubricate and reseat the connectors.

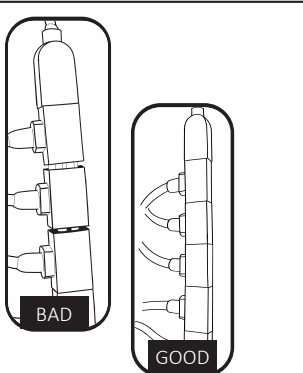

3

Pre Dive Check List

Using the Controller / Testing the System:

1. Verify all thrusters respond to the controller inputs as expected. (M) (J)
2. Verify main camera tilts all the way up and all the way down. (F) (G)
3. Verify main camera focus - in and out. (H) (I)
4. Verify LED light function. Both LED modules dim until off and increase until full illumination. (E)
5. Deploy Vehicle and adjust ballast.
NOTE: It is okay to lower the vehicle using the tether

To ballast the ROV: Add or remove ballast weights **12** until the ROV is slightly positively buoyant. Typically, this is achieved when the top of the float block is even with the water surface.

6. Enable auto controls (they will turn green when enabled).

Auto-Depth



Auto-Heading



7. Begin operations and recording.

Views

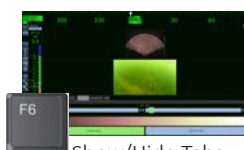
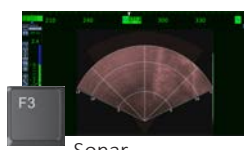
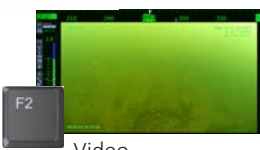
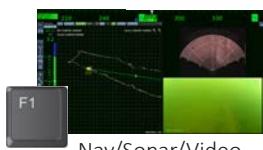

Thruster / Propeller Reference

Propeller Identification



LEFT

The LEFT propeller has a black plastic base



RIGHT

The RIGHT propeller has a stainless band at its base

Correct Propeller Type for each Location

PORT

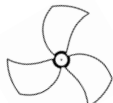

LEFT

VERTICAL



RIGHT

STARBOARD

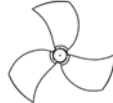

RIGHT

Vertical (looking down on the vehicle from the rear)

Horizontal (looking from behind the vehicle)

4

Hand Controller Input Identification

NOTE: Xbox Elite hand controller compatibility coming soon



- | | |
|----------------------------|-------------------------------|
| A. All Autos Off | I. Focus Out |
| B. Open Manipulator Jaws | J. Vehicle Horizontal Control |
| C. Close Manipulator Jaws | K. Camera Snapshot |
| D. Rotate Manipulator Jaws | L. Camera Record |
| E. Lights Intensity | M. Vehicle Vertical Control |
| F. Camera Tilt Up | N. Sonar Frequency Selection |
| G. Camera Tilt Down | O. Increase Sonar Range |
| H. Focus In | P. Decrease Sonar Range |

5

Recovering the System Post Dive Check List



1. Navigate the vehicle back to the deployment site.
2. Disable auto controls and stop recording.

Auto-Depth



Auto-Heading



3. Retrieve the ROV.
NOTE: It is okay to lift it by the tether.
4. Close the Greensea EOD Workspace by clicking on the red X on the top right corner of the EOD Workspace window. 
5. Press the ROV Mains Power Switch. 
6. Turn off the Operator Control Console using the Power Switch. 
7. Disconnect the tether from the ROV.
8. Disconnect the tether from the OCC whip.
9. Replace the tether caps on all tether connections.
10. Visually inspect the system for damage that might have occurred during your operation.
11. Rinse the salt water from the system and soak the submersible for 30 minutes in fresh water.
12. Return all components to their storage cases after they have dried.

Verify System Connectivity

- 13. Heading - The Compass Bar will turn green when connected. 29
- 14. Depth - The Depth Tracker will turn green when connected. 30
- 15. Sonar - Imagery will display in the sonar window when the sonar has connected. 31
- 16. Video - Imagery will appear in the video window when the camera has connected. 32

USBL Installation

NOTE: The USBL is an optional accessory
NOTE: If not using the USBL, make sure the ROV connector port is sealed

- 17. Remove the float block. 1
- 18. Feed the USBL accessory cable through the GPS hole in the float block.
- 19. Connect the accessory cable to the power / communications module port.
- 20. Replace the float block and secure the USBL beacon using the rear float block screw. 14
- 21. Connect the Topside GPS Antenna to one of the Accessory USB Ports on the OCC. 28
- 22. Connect the USBL Topside Station to the OCC by plugging it into the Auxiliary 12 V Port for power 27 and the Accessory USB Port for communications. 28
- 23. Deploy the USBL Topside Station in the water.

The OCC



Greensea Software

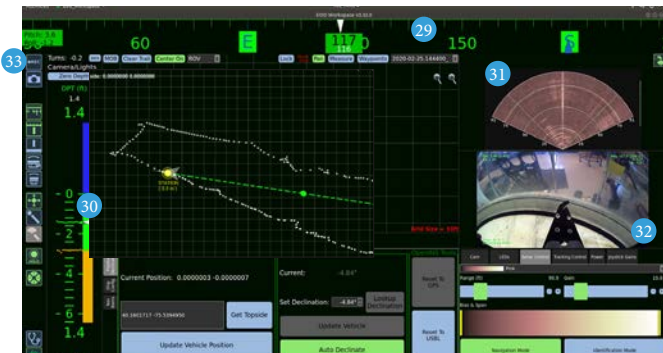

Pro 5 Component Identification

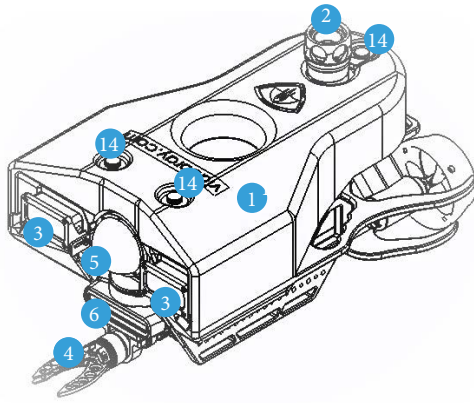

1. Float *part number 70779*
2. USBL Beacon --(optional) *part number 70693*
3. LED Lighting Module *part number 70023 (QTY 2)*
4. Rotating Manipulator *part number 70824*
5. HD Camera Module *part number 70044*
6. Multibeam 750D Sonar *part number 71047*
7. Vertical Thruster *part number 70503*
8. Port Thruster *part number 70503*
9. Starboard Thruster *part number 70503*
10. Pro 5 Power and Comms Module *part number 71006*
11. AHRS Module *part number 70273*
12. Ballast *part number 71044*
13. Serial Number Plate
14. Float Block Screw
15. Operator Control Console (OCC) *part number 70218*

16. High Definition Display
17. Display Brightness
18. Universal Power Plug 100-124 volts AC
19. OCC Power On|Off Switch
20. ROV Power Mains/Emergency Stop
21. Line Insulation Monitor
22. HDMI Ports

23. Auxiliary Ethernet Port
24. Controller USB Port
25. Keyboard USB Port
26. Tether Whip Connection
26A-26B. Tether Double Ended Connector
27. Auxiliary 12 Volts (5 amp max)
28. Accessory USB Ports
29. Compass Bar
30. Depth and Altitude Tracker
31. Sonar feed
32. Video feed
33. Record button
34. Strain relief bolt
35. Test strain relief

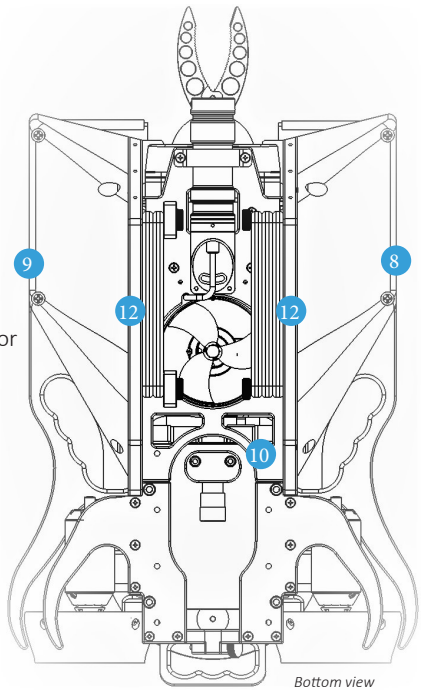

Bottom view

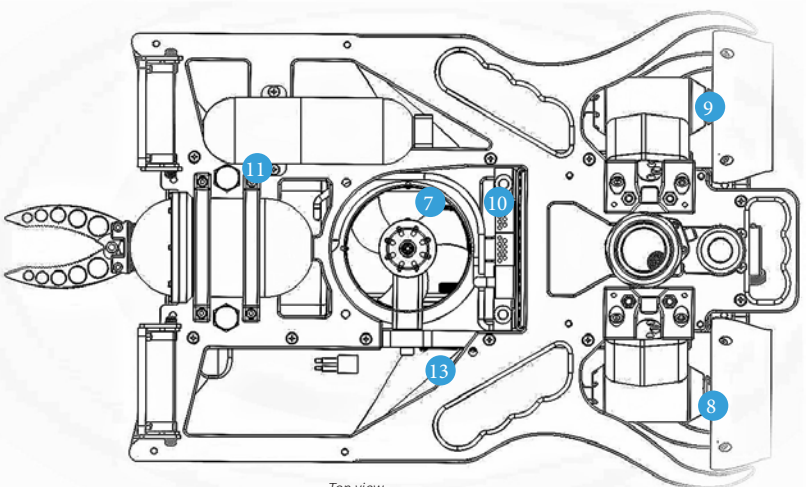

Top view